

MaxMotion

IEC PERFORMANCE DATA SHEET IEC Efficiency Level IE3

Catalog #: **IJC180L-4-46**

HP	kW	Voltage	L.R. Amps	Efficiency	Power Factor	Service Factor	Frame	Design
30,00	22,38	230 / 460	257,25	93,6%	0,86	1,15	180L	N

60 Hz								
FLA							Is/In	F.L. RPM
208	230	333	460	575	796	990		
/	68,60	/	34,30	/	/	/	7,5	1760

50 Hz								
FLA						Efficiency	Is/In	F.L. RPM
190	380	400	415	660	725			
83,60	41,80	39,71	38,30	/	/	93,0%	7,5	1470

Wgt. Lbs	PH	Duty	Insul. Class	Ambient Temp.	Elevation	Temp. Rise° C
467	3	S1	H	40°C	1000 M	60

% Efficiency		% Power Factor		Torque			Protector Type	Winding Resist. Ω
Full Load:	93,6%	Full Load:	0,86	FLT ft.lbs	60Hz	50Hz		
3/4 Load:	89,8%	3/4 Load:	0,73	LRT %	220	220	PTC-150°C	-
1/2 Load:	81,5%	1/2 Load:	0,56	BDT %	230	230		

Rotor Inertia Wk2 Lb-Ft2	Max Load Inertia Wk2 Lb-Ft2	Shaft Material	Frame Material	DE Bracket Type	ODE Bracket Type	Mounting	Enclosure	Protection
-	-	Standard	Cast Iron	Standard	Standard	B3	TEFC	IP55

Ball Bearings		Grease	Mount Type	Orientation	Cold Start (Secs)	Paint
DE	ODE					
6311-C3	6311-C3	Mobil PolyRexEM	Rigid	Horizontal	15	Red

Inverter Duty. Motor meets MG1 parts 31.4.4.2	Constant Torque Range	Variable Torque Range
	10:1	20:1

WIRING CONNECTION DIAGRAM : C

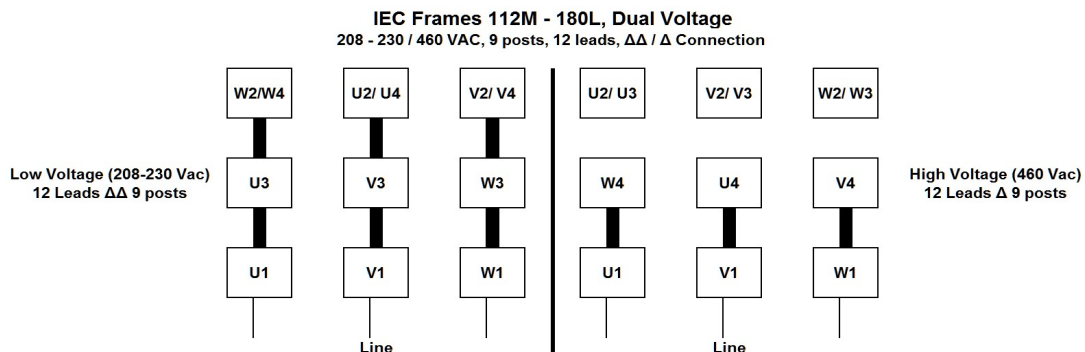

Date: **25 janvier, 2024**
 Customer: _____
 Contact: _____
 Submittee: **J.C. Lavallée**

Catalogue #: **IJC180L-4-46**

IEC Efficiency Level IE3											
HP	Kw	VAC	RPM	Enclosure	Frame	Frequency	Design	Poles	LR Is/In	Insulation Class	Temp. Rise °C
30,00	22,38	230 / 460	1760	TEFC	180L	60	N	4	7,5	H	60
		0Hz	6Hz	15Hz	30Hz	45Hz	60Hz	75Hz	90Hz	105Hz	120Hz
Amps		34,30	34,30	34,30	34,30	34,30	34,30	34,30	34,30	34,30	34,30
RPM		0	176	440	880	1320	1760	2200	2640	3080	3520
Torq ft.lb		71,62	89,52	89,52	89,52	89,52	89,52	71,62	59,68	51,16	44,76
Peak Tq ft.lb		96,24	192,47	192,47	192,47	192,47	192,47	153,98	128,32	109,99	34,30
HP		0,00	3,00	7,50	15,00	22,50	30,00	30,00	30,00	30,00	30,00
		Locked Rotor	Pull-Up	Breakdown	Rated Load	Idle	Duty	S. F.	Ambient	Elevation	dBA @ 1M
Speed (RPM)		0	810	1350	1760	1800	S1	1,15	40°C	3,300 ft	-
Current (Amps)		257,25	205,80	144,06	34,30	27,70	VFD Rating: Meets MG1 parts 31.4.4.2				
Torque (ft-lbs)		196,95	167,41	205,90	89,52	0,0	CT :	10:1	VT :	20:1	

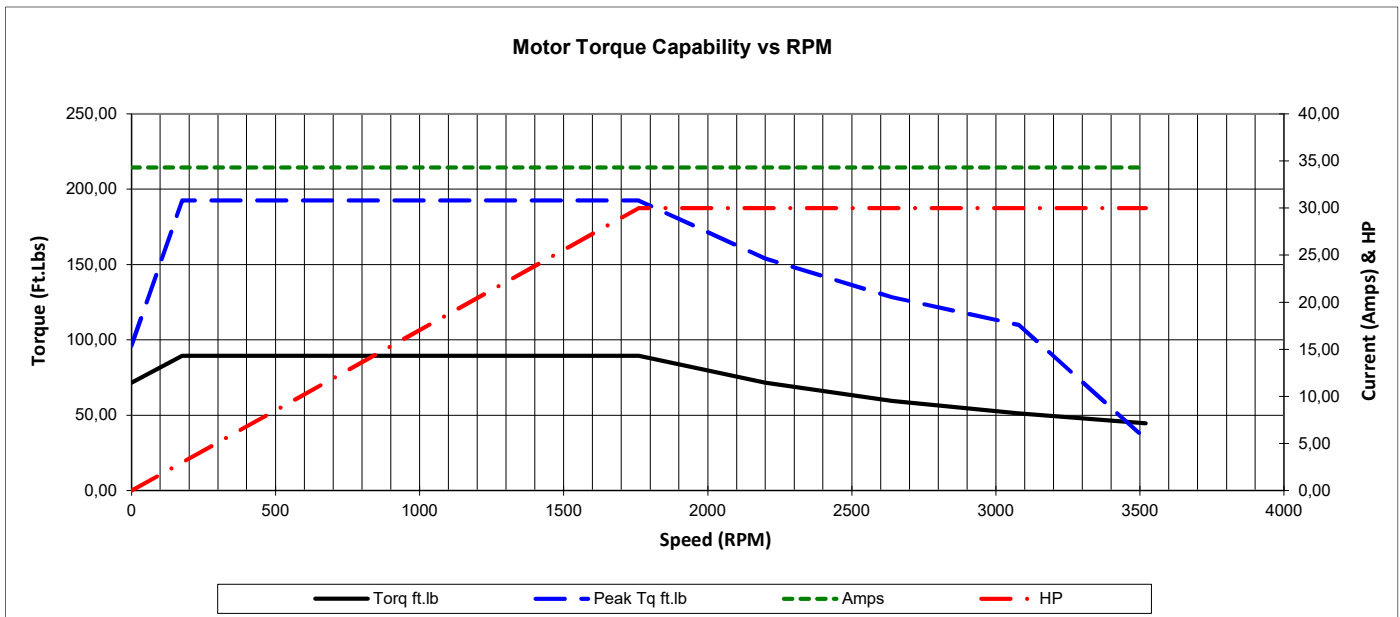
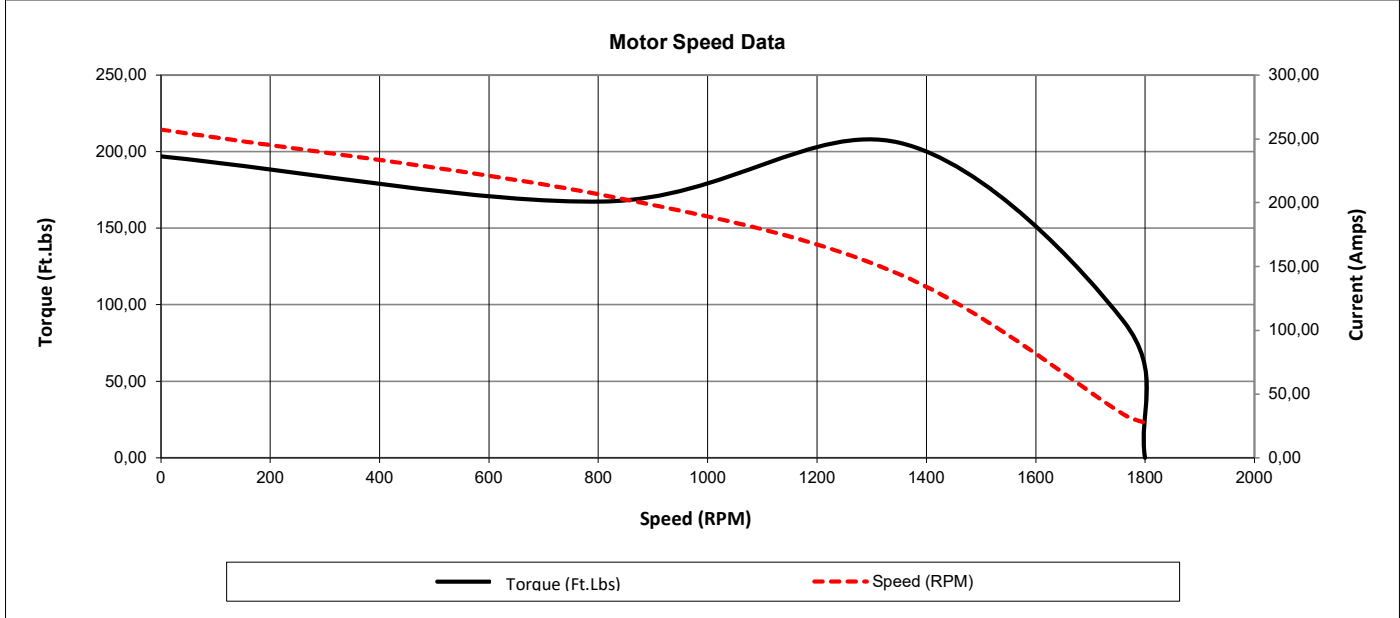

Date: **25 janvier, 2024**
 Customer: _____
 Contact: _____
 Submittee: **J.C. Lavallée**

Catalogue #: **IJC180L-4-46**

IEC Efficiency Level IE3											
HP	Kw	VAC	RPM	Enclosure	Frame	Frequency	Design	Poles	LR Is/In	Insulation Class	Temp. Rise °C
30,00	22,38	230 / 460	1760	TEFC	180L	60	N	4	7,5	H	60

Load %	0%	25%	50%	75%	100%	125%	150%
Amps	27,70	27,70	30,34	31,66	34,30	39,58	50,13
Torq ft/lbs	0	22,01	44,26	66,76	89,52	116,69	149,87
RPM	0	1790	1780	1770	1760	1688	1577
Eff %	0	61,0	81,5	89,8	93,6	91,2	83,8
PF %	0	39,3	55,7	72,7	86,0	88,6	90,3

	Locked Rotor	Pull-Up	Breakdown	Rated Load	Idle	Duty	S. F.	Ambient	Elevation	dBA @ 1M
Speed (RPM)	0	810	1350	1760	1800	S1	1,15	40°C	3,300 ft	-
Current (Amps)	257,25	205,80	144,06	34,30	27,70	VFD Rating: Meets MG1 parts 31.4.4.2				
Torque (ft-lbs)	196,95	167,41	205,90	89,52	0,0	CT :	10:1	VT :	20:1	

